

Thank you for purchasing PA Quantum Electronic Speed Controller (ESC)

High power systems for RC model can be very dangerous and we strongly suggest that you read this manual carefully. Precision Aerobatics have no control over the use, installation, application, or maintenance of these products, thus no liability shall be assumed nor accepted for any damages, losses or costs resulting from the use of this item. Any claims arising from the operating, failure or malfunctioning etc. will be denied. We assume no liability for personal injury, property damage or consequential damages resulting from our product or our workmanship. As far as is legally permitted, the obligation for compensation is limited to the invoice amount of the product in question.

Specification:

	Quantum 18	Quantum 30	Quantum 45
Continuous current	18A	30A	45A
Burst Current (<10s)	22A	35A	55A
BEC Output Linear (Peak Loads 10sec)	5V/3A (max) 3A @ 7.4 V, 2A @ 11.1V	5V/4A (max) 4A @7.4V, 3A @11.1V	5V/4A (max) +4A @7.4V, 3A @11.1V
BEC Output Linear (Continuous Loads)	3A @ 7.4 V (4 micro servos)	3A @7.4V (5 micro servos)	3A @7.4V (5 micro servos)
	1.5A @ 11.1V (4 sub-micro servos)	2A @11.1V (4 micro servos)	2A @11.1V (4 micro servos)
Li-ion/ LiPo	2-3 Cells	2-4 Cells	2-4 Cells
NiMh/NiCd	5-10 Cells	5-12 Cells	5-12 Cells

Note: The PA Quantum 30 & 45 BEC has 4 power regulator chips (Quantum 18 has 3). The 4 power regulator chips support the high torque micro servos in the most demanding load-conditions imposed during aggressive 3D and freestyle aerobatics, providing bulletproof reliability.

This form of flying is where servos actuating oversized control surfaces may momentarily stall under extreme aerodynamic loads that would cause most low and medium power BECs to overheat and shutdown resulting in catastrophic loss of control.

The PA Quantum ESC's high power BEC has been specifically designed for extreme aerobatics and therefore has the capability to support the higher momentary peak demand loads to eliminate the possibility of unwanted shutdowns. This high power BEC is also capable of supporting continuous simultaneous multiple servo operations typically found in CCPM equipped hardcore 3D E-helicopters.

Features:

- ◆ Extremely low internal resistance
- ◆ Super smooth and accurate throttle linearity
- ◆ Safety thermal over-load protection
- ◆ Auto throttle shut down in signal lose situation
- ◆ Supports high RPM motors
- ◆ Power arming protection (prevents the motor from accidentally running when switched ON)
- ◆ NEW Advanced programming software

Our ESC allows you to program all functions to fit your specific needs, which makes it very efficient and user friendly:

1. User programmable brake setting (we recommend using brake for only folding props applications)
2. User programmable battery type (LiPo or NiCd/NiMh)
3. User programmable low voltage cutoff setting
4. User programmable factory default setup restore
5. User programmable switching frequency
6. User programmable low voltage cutoff type (power reduction or immediate shutdown)
7. User programmable timing settings (to enhance ESC efficiency and smoothness)
8. User programmable soft acceleration start ups (for delicate gearbox and helicopter applications)
9. User programmable motor rotation (clockwise\counterclockwise)
10. User programmable governor mode (for helicopter applications)

Wiring Diagram:

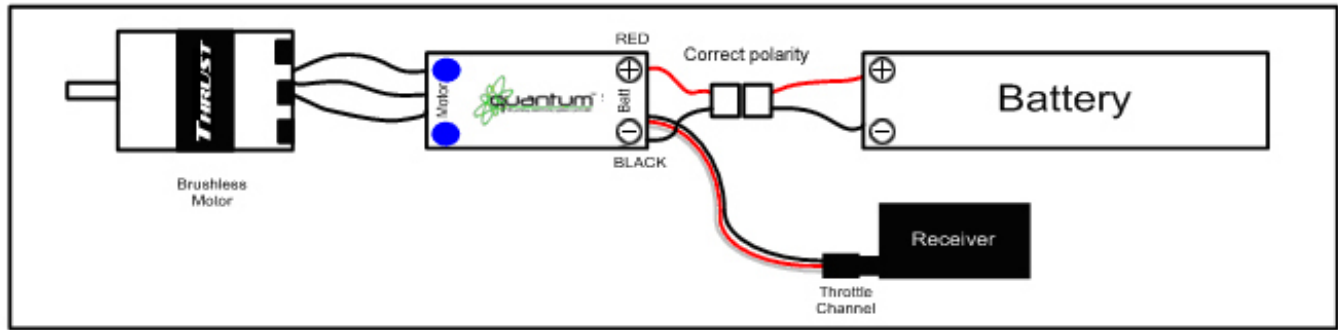

Settings:

1. Brake: ON/OFF

ON- Sets the propeller to the brake position when the throttle stick is at the minimum position (Recommended for folding props).

OFF- Sets the propeller to freewheel when the throttle stick is at the minimum position.

2. Battery type: LiPo or NiCad/NiMh

NiCad/NiMh - Sets Low Voltage protection threshold for NiCad/NiMh cells.

LiPo - Sets Low voltage protection threshold for LiPo cells and automatically detects the number of cells within the pack.

Note: Selecting the NiCad/NiMh option for the battery type, triggers the ESC to automatically set the cutoff threshold to the factory default of 65%. The cutoff threshold can then be subsequently altered through the *Low Voltage protection* function, if required. The ESC will read the initial voltage of the NiCad/NiMh pack once it is plugged in and the voltage read will then be used as a reference for the cutoff voltage threshold.

3. Low Voltage Protection Threshold (Cutoff Threshold): Low / Medium / High

1) **For Li-xx packs-** number of cells are automatically calculated and requires no user input apart from defining the battery type. This ESC provides 3 setting options for the low voltage protection threshold; Low (2.8V)/ Medium (3.0V) / High (3.2V). For example: the voltage cutoff options for an 11.1V/ 3 cell Li-Po pack would be 8.4V (Low)/ 9.0V (Med)/ 9.6V (High).

2) **For Ni-xx packs-** low / medium / high cutoff voltages are 50%/65%/65% of the initial voltage of the battery pack. For example: A fully charged 6 cell NiMh pack's voltage is $1.44V \times 6 = 8.64V$, when "LOW" cutoff voltage is set, the cutoff voltage is: $8.64V \times 50\% = 4.3V$ and when "Medium" or "High" is set, the cutoff voltage is now $8.64V \times 65\% = 5.61V$.

4. Restore factory setup defaults:

Restore- Sets the ESC back to factory default settings; i.e.

Brake	:	Off
Battery type	:	LiPo with Automatic Cell Detect
Low voltage cutoff threshold:	:	Medium (3.0V/65%)
Frequency	:	8kHz
Low voltage cutoff type	:	Reduce power
Timing setup	:	Automatic
Soft Acceleration Start Up	:	Disabled
Governor mode	:	Disabled

5. Switching Frequency: 8kHz/16kHz

8kHz - Sets ESC switching frequency for 2 pole motors, e.g. in-runners.

16kHz- Sets ESC switching frequency for motors with more than 2 poles, e.g. out-runners.

Although 16kHz is more efficient with our Thrust motors, the setup default is 8kHz due to the higher RF noises caused at 16kHz.

6. Low Voltage Cutoff Type: Reduce Power / Hard cutoff

Reduce Power – ESC reduces motor power when the pre-set Low Voltage Protection Threshold value is reached (recommended).

Hard Cutoff – ESC instantly cuts motor power when the pre-set Low Voltage Protection Threshold value is reached.

7. Timing setup: Low / Automatic / High.

- * **Low (0 – 7deg)** - Setting for most 2 pole motors.
- * **Automatic** - ESC automatically determines the optimum motor timing
- * **High (22-30 deg)** - Setting for motors with 6 or more poles.

In most cases, automatic timing works well for all types of motors. However for high efficiency we recommend the Low timing setting for 2 pole motors (general in-runners) and high timing for 6 poles and above (general outrunners). For higher speed, High timing can be set. Some motors require different timing setups therefore we suggest you to follow the manufacturer recommended setup or use the automatic timing setting if you are unsure.

Note: Run your motor on the ground first after making any changes to your motor timing!

8. Soft Acceleration Start ups: Disable / Soft

Disable – Provides quick acceleration start ups with a linear throttle response. This is recommended for fixed wing models fitted with direct drive setups.

Soft – Provides initial slow 1 sec ramp-up from start to full rpm intended to protect delicate gears from stripping under instant load. This setting is recommended for either fixed wing models equipped with gearboxes and/or helicopters.

9. Motor Rotation: Reverse

In most cases motor rotation is usually reversed by swapping two motor cables over. However, in cases where the motor cables have been directly soldered to the ESC cables, motor rotation can be reversed by changing the value of this setting on the ESC.

10. Governor Mode: Disable / Enable (Helicopter application)

Disable- disables the governor mode, **Enable**- enables the governor mode.

Note: Once the Governor Mode is enabled, the ESC's Brake and Low Voltage Cutoff Type settings will automatically be reset to No Brake and Reduce Power respectively regardless of what settings they were previously set.

Using Your New ESC

Improper polarity or short circuit will damage the ESC therefore it is your responsibility to double check all plugs for proper polarity and firm fit BEFORE connecting the battery pack.

Alert Tones

The PA Quantum ESC is equipped with audible alert tones to indicate abnormal conditions at power up.

1. Continuous beeping tone (****) - Indicates that throttle stick is not in the minimum position.
2. Single beeping tone followed by a one second pause (* * * *) - Indicates that the battery pack voltage is not within the acceptable range. (The ESC automatically checks and verifies the battery voltage once the battery is connected).
3. A single beeping tone followed by a short pause (* * * *) – Indicates that the ESC is unable to detect the normal throttle signal from the receiver.

Built-in Intelligent ESC Safety Functions

1. **Over-heat protection:** When the temperature of ESC exceeds 110 deg C, the ESC will reduce the output power to allow it to cool.
2. **Lost Throttle signal protection:** The ESC will automatically reduces output power to the motor when it detects a lost of throttle signal for 2 second, a subsequent loss of throttle signal beyond 2 seconds, will cause the ESC automatically to cut power to the motor.

Powering up the ESC for the first time and setting the Automatic Throttle Calibration

The PA Quantum ESC features Automatic Throttle Calibration to attain the smoothest throttle response and resolution throughout the entire throttle range of your transmitter. This step is done once to allow the ESC to "learn and memorize" your Transmitter's throttle output signals and only repeated if you change your transmitter.

1. Switch your Transmitter **ON** and set the throttle stick to its **minimum** position.
2. Adjust the throttle trim all the way down to the minimum position.

3. Verify the throttle travel adjust (ATV) to be set at 100% span.
4. Disable any throttle mix or curves in the transmitter. (For Futaba radios set the throttle channel to Reverse)
5. Connect the battery pack to the ESC.
6. Adjust your throttle trim up until the motor starts spinning.
7. Then adjust your throttle trim a few clicks down until the motor stops spinning.

The throttle is now calibrated and your ESC is ready for operation.

Normal ESC start up procedure:

1. Switch your Transmitter **ON** and set the throttle to its **minimum** position.
2. Connect the battery pack to the ESC.
3. When the ESC is first powered up, it emits two sets of audible tones in succession indicating the status of its programming state.
 - o The first set of tones denotes the number of cells in the LiPo pack connected to the ESC. (Three beeps (***) indicates a 3 cell LiPo pack while 4 beeps (****) indicates a 4 cell LiPo pack).
 - o The second set denoting Brake status (one beep (*) for Brake "ON" and two beeps (**) for Brake "OFF").
 - o The ESC then automatically calibrates the throttle range.
 - o The ESC is now ready for use.

Note: Should the audible tone be any different than what is stated above, please refer to the *Alert Tones* and *Built-in Intelligent ESC Safety Functions* section of this manual.

Entering the Programming Mode:

1. Switch your Transmitter **ON** and set the throttle to its **maximum** position.
2. Connect the battery pack to the ESC.
3. Wait until you hear two long audible tones followed by two short beeps (_ _ **) confirming that the ESC has now entered the programming mode.
4. If within 5 seconds, the throttle stick is lowered to its **minimum** position, an audible tone is emitted confirming that the brake setting has changed. If the throttle stick is left in the **maximum** position beyond 5 seconds, the ESC will begin the sequence from one function and its associated setting options to another. (Please refer to the table below to cross reference the functions with the audible tones).
5. When the desired tone for the function and setting option is reached, move the throttle stick down to its **minimum** position. ESC will emit two beeps (* *) confirming the new setting has been stored.
6. The ESC only allows the setting of one function at a time. Therefore should you require making changes to other function, disconnect the battery pack and wait 5 seconds to reconnect the battery and repeat the above steps.

General Safety Precautions

- Do not install the propeller (fixed wing) or drive pinion (helicopter) on the motor when you test the ESC and motor for the first time to verify the correct settings on your radio. Only install your propeller or pinion after you have confirmed that the settings on your radio is correct.
- Never use ruptured or punctured battery cells.
- Never use battery packs that are known to overheat.
- Never short circuit battery or motor terminals.
- Always use proper insulation material for cable insulation.
- Always use proper cable connectors.
- Do not exceed the number of cells or servos specified by the ESC.
- **Wrong battery polarity will damage the ESC and void the warranty.**
- Install the ESC in a suitable location with adequate ventilation for cooling. This ESC has a built-in over temperature cutoff protection feature that will immediately cut power to the motor once the ESC temperature exceeds the 230 Deg F/ 110 Deg C high temperature limit.
- Use only batteries that are supported by the ESC and ensure the correct polarity before connecting.
- Switch your Transmitter ON and ensure the throttle stick is in the minimum position before connecting the battery pack.
- Never switch your transmitter **OFF** while the battery is connected to your ESC.
- Only connect your battery pack just before flying and do not leave your battery pack connected after flying.
- Handle your model with extreme care once the battery pack is connected and keep away from the propeller at all times. Never stand in-line or directly in front of any rotating parts.
- Do not immerse the ESC underwater while powered up.
- Do fly at a designated flying site and abide by the rules and guidelines set by your flying club.

PA Quantum ESC Programming Chart

Audible Tones for Normal Start

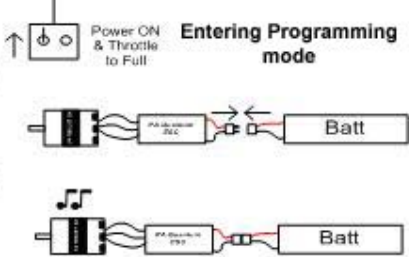
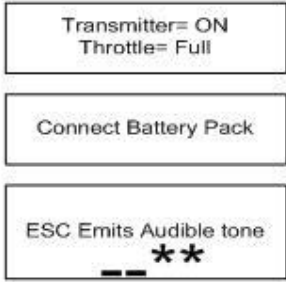
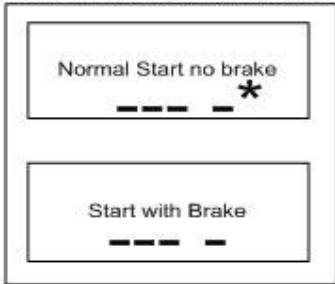

Programming Mode Audible Tones	ESC Functions
Brake	
(Within the first 5 Sec) *	Brake ON
(Within the first 5 Sec) _ *	Brake OFF
Battery type	
* * * *	NiCad
** ** ** **	Lipo
Low Voltage Cutoff Threshold	
* _ * * _ * * _ * * _ *	Low
* _ _ * * * _ * * _ * * _ *	Medium
* _ _ _ * * _ * * _ * * _ *	High
Restore Factory Setup Defaults	
_ _ _ _	Restore
Switching Frequency	
♪♪♪♪	8kHz
♪♪♪♪	16kHz
Low Voltage Cut Off Type	
_ _ _ _	Reduce Power
_ _ _ _	Hard Cut Off
Timing Setup	
_ _ _ _	Low
_ _ _ _	Automatic
_ _ _ _	High
Soft Acceleration Start Ups	
♪♪♪♪	Disable
♪♪	Soft
Motor Rotation	
♪♪♪♪	Reverse
Governor Mode	
* _ * _ * _ * _	Disable
** _ ** _ ** _ ** _	Enable

Note: ↓ [ESC Icon] OK = Store Parameter and End Programming



Trouble Shooting

Trouble	Possible Reason	Action
Motor doesn't work and no audible tone emitted after connecting the battery. Servos are not working either.	Poor / loose connection between battery pack and ESC.	Clean connector terminals or replace connector.
	No power	Replace with a freshly charged battery pack
	Poor soldered connections (dry joints)	Re-solder the cable connections
	Wrong battery cable polarity.	Check and verify cable polarity
	ESC throttle cable connected to receiver in the reverse polarity.	Check the ESC cable connected to the ESC to ensure the connectors are in the correct polarity.
	Faulty ESC	Replace ESC
Motor doesn't work and no audible tone emitted after connecting the battery BUT servos are working.	Poor / loose connection between ESC and motor	Clean connector terminals or replace connectors
	Burnt motor coils	Replace motor
	Poor soldered connections (dry joints)	Re-solder the cable connections
Motor doesn't work after powering up the ESC. An alert tone with two beeping tones followed by a short pause (** ** ** **) is emitted.	The battery pack voltage is not within the acceptable range.	Replace with a freshly charged battery pack Check battery pack voltage
Motor doesn't work after powering up the ESC. An alert tone with a single beeping tone followed by a short pause (* * * *) is emitted.	The ESC is unable to detect the normal throttle signal from the receiver	Check and verify that the ESC cable is connected to the <u>Throttle</u> channel on the receiver. Check the transmitter and receiver to verify that there is throttle signal output. (Connect a spare servo to verify throttle channel operation)
Motor doesn't work after powering up the ESC. An alert tone with continuous beeping tones (****) is emitted.	The throttle stick is not in the <u>minimum</u> position at power up.	Move the throttle stick to the minimum position.
Motor doesn't work after powering up the ESC. ESC emits two long audible tones followed by two short beeps (_ _ **)	Reversed throttle channel caused the ESC to enter the programming mode.	Enter the servo reverse menu on your transmitter and reverse the throttle channel. Note: For Futaba radios set the throttle channel to Reverse.
Motor runs in reverse rotation	Wrong cables polarity between the ESC and the motor.	Swap any two of the three cable connections between the ESC and the Motor <u>or</u> access the Motor Rotation function via the ESC programming mode and change the pre-set parameters.
Motor stops running in flight.	Lost throttle signal	Check proper operation of the radio equipment. Check the placement of the ESC and the Receiver and check the route of the receiver's aerial and ESC cables to ensure there is adequate separation to prevent RF interference. Install a ferrite ring on the ESC's throttle cable.
	Battery Pack voltage has reached the Low Voltage Protection threshold.	Land the model immediately and replace the battery pack.
	Possible bad cable connection	Check and verify the integrity of the cable connections
Motor restarts abnormally	Possible RF interference at the flying field.	The normal operation of the ESC may be susceptible to surrounding RF interference. Restart the ESC to resume normal operation on the ground to verify recurrence. If the problem persists, test the operation of the ESC at a different flying field.
ESC Overheats	Inadequate Ventilation	Relocate the ESC to allow better ventilation
	Servos drawing too much current and over loading the ESC.	Use servos that are adequately sized for the ESC. The maximum BEC current drawn should be within the BEC limits.
	Over sized motor or prop	Prop down or resize the motor